



Mini-Max M235 Series Digital Panel Meter

- **Minimum Depth Indicator - Less Than 2.5" (60mm) of Space Required Behind the Panel**
- **Stackable Mounting Bracket Included for Easy Installation**
- **LCD: 3-1/2 Digit, 0.5" (12.7mm) High LCD Display with Optional Negative Image, Bright Red Backlighting**
- **LED: 3-1/2 Digit 0.56" (14.2mm) High Display**
- **Limited Range Display Scaling**
- **Standard Screw Terminals for Easy Installation**
- **LCD: Four Voltage Ranges: 200mV, 2V, 20V, 200V**
- **LED: Five Voltage Ranges: 200mV, 2V, 20V, 200V, 600V**
- **85-250V AC or Optional 9-32V DC Power Supply**



LCD



LED

Simpson's Mini-Max Voltage Indicators provide high quality, accuracy, and reliability in a compact, 60mm deep case.

LCD (Liquid Crystal Display) Units offer 3-1/2 digit, 0.5" (12.7mm) LCD display with an optional bright red, negative image backlight.

LED (Light Emitting Diode) Units offer a 3-1/2 digit 0.56" (14.2mm) Display.

All units feature user-selectable decimal point, auto zero and limited scaling capabilities.

A unique mounting bracket is provided to allow for vertical or horizontal stacking of multiple indicators. All Mini-Max units feature a 3/64 DIN, high-impact plastic case. The LCD units have a Clear viewing window, and the LED units have a Red viewing window.

Installation and Panel Cutout

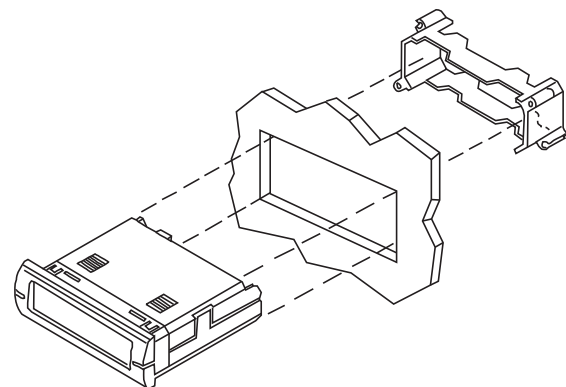
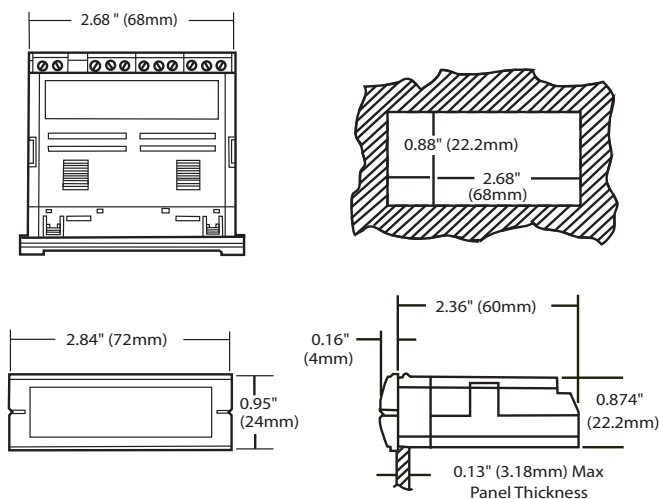

Mounting Requirements

Insert the Mini-Max through the panel, and then slide the mounting bracket onto the Mini-Max. The mounting bracket allows Mini-Max units to be stacked side-to-side or top-to-bottom and maintain the DIN standard panel arrangements in 24mm by 72mm multiples. Panel cutout instructions for stacking multiple units are provided under "Stacking Features."

Specifications

DISPLAY

Type: 7-segment LCD or LED
Height: LCD 0.5" (12.7mm)
 LED 0.56" (14.2mm)

Decimal point: 3-position selectable

Overrange indication:

LCD Most significant digit = "1"
 LED Blinking Display

LCD Backlighting: Optional negative image, red backlight

Polarity: Auto with "-" indication, "+" implied

Power Requirements:

AC Volt: 85-250VAC @40-440Hz
DC Volt: 9-32VDC

Power Consumption: (Non Fused)

85-250VAC: LCD 4.0VA (2.4W) Max
 LED 3.6VA (2.16W) Max

9-32VDC: LCD 3 W Max
 LED 2W Max

Isolation: 250VRMS Max

Noise Rejection

CMRR: 86dB Typical

ACCURACY @ 25°C

±(0.1% of Reading ±1 count)

ENVIRONMENTAL

Operating Temperature: 0 to 55°C

Storage Temperature: -10 to 60°C

Relative Humidity: 0 to 85%

non condensing @ 40°C

Temperature Coefficient:

(0.2% of input ± 0.5 digits)/ °C

Warmup time: Less than 20 minutes

Analog to Digital Conversion

Technique: Integrating Dual Slope

Rate: 3 samples/second-typical

Mechanical

Bezel: 0.95" x 2.84" (24mm x 72mm)

Depth: 2.36" (60mm)

Panel cutout: 0.88" x 2.68"(22.2mm x 68mm)

Weight: LCD 3.5oz (99.2g)

LED 2.6oz (74g)

Case Material: 94-0, UL-rated, glass-filled thermoplastic

DCV

Range	Resolution M235	Input Impedance	Max Input Unfused
200mV	100uV	10MEG	100Vdc
2V	1mV	10MEG	250Vdc
20V	10mV	10MEG	250Vdc
200V	100mV	9.9MEG	250 Vdc
600V	1V	9.9MEG	600Vdc



DP3 DP2 DP1

Connections

LCD VERSIONS

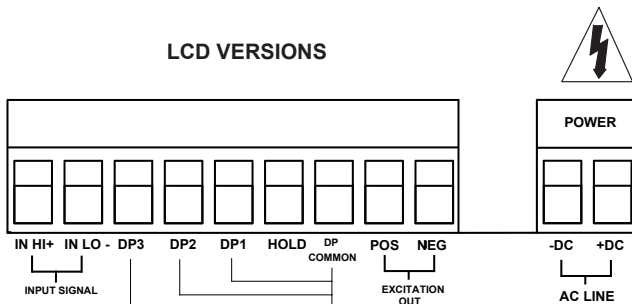

LED VERSIONS

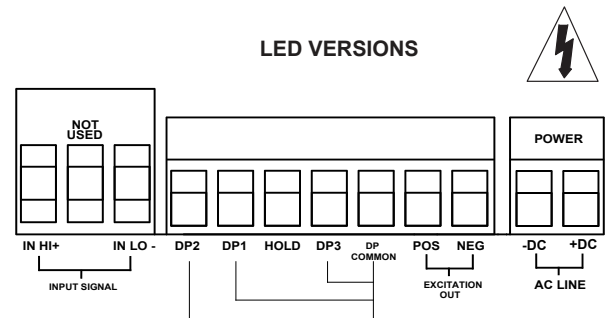

WARNING: These instruments are designed for maximum safety to the operator when mounted in a panel according to instructions. They are not to be used unmounted or for exploratory measurements in unknown circuits.

Input Signal: Connect the DC signal to be monitored to the **IN HI +** and **IN LO -** input terminals.

Input Power: For AC power, connect the AC POWER LINE to the **AC LINE** inputs. For optional DC power, connect the DC Supply to the DC inputs. Observe polarity.

Decimal Point: To select a decimal point, connect the appropriate DP input pin (DP1 - DP3) to the DP COMMON output. Unused DP inputs may remain unconnected (open).

Hold Option: Connect the DP COMMON output to the **HOLD** input. If this feature is not required, the HOLD pin may remain unconnected.

LCD Backlight Option: Negative image, bright red backlighting is available for the LCD versions only. This illumination allows the unit to be read in low light areas. Backlighting power is supplied by the Mini-Max, so no additional external power is required.

Excitation Option: Excitation is available at the **EXCITATION OUT** Positive (**POS**) and Negative (**NEG**) terminals for powering external transmitters or transducers. This source is isolated from the measurement input as well as the input power circuits. The voltages available are 12Vdc or 24Vdc with a maximum load current of 25mA. This feature eliminates the need to mount an external DC power source for transducers or sensors used in your application.

Display Scaling

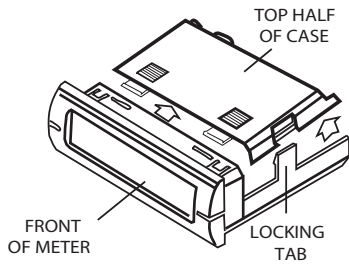

Using a screwdriver or thumbnail, spread the tabs on each side of the case to unlock the top half. Lift the rear of the top half and slide it away from the front of the meter.

Scale Adjustment:

Mini-Max indicators have limited range coarse and fine adjustments for display scaling. There are no optional connections required for these to function. The meter can be scaled down to 1/2 the value of the input, or scaled up to 2 times the value of the input, or a maximum reading of 1.999, whichever is lower.

Example: A 2 volt input has a maximum reading of 1.999 counts, so you cannot double the 2 volts, but you can make a 1 volt input read 1.999.

LCD VERSIONS

Scale Adjustment:

The "Coarse" adjustment R12 will allow a limited range of adjustment values. The "Fine" adjustment R9 allows for an adjustment range of approximately 1% of the "Coarse" adjustment. Apply the full scale input to the meter. Adjust R12 to be within 1% of the desired result. Then use R9 to obtain the final desired result.

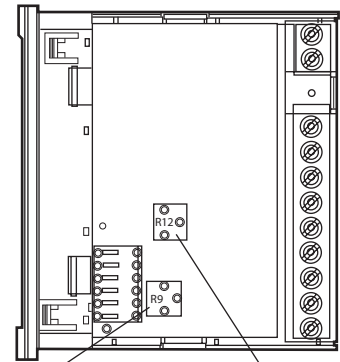

SCALE ADJ.
FINE

SCALE ADJ.
COARSE

Note: Any physical damage to the meter during adjustment will void the warranty.

LED VERSIONS

Scale Adjustment:

The "Coarse" adjustment RV1 will allow a limited range of adjustment values. The "Fine" adjustment RV2 allows for an adjustment range of approximately 1% of the "Coarse" adjustment. Apply the full scale input to the meter. Adjust RV1 to be within 1% of the desired result. Then use RV2 to obtain the final desired result.

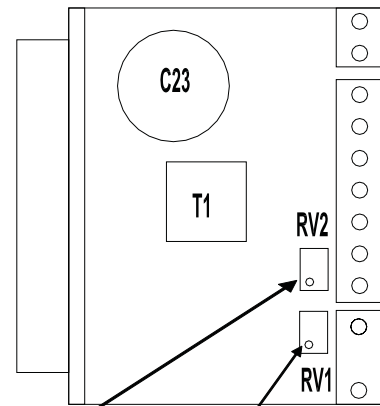

SCALE ADJ.
FINE

SCALE ADJ.
COARSE

Note: Any physical damage to the meter during adjustment will void the warranty.

Stacking Features

The mounting bracket, included with every Mini-Max, can be connected together. Multiple units can be mounted in a single opening, allowing perfect alignment.

To punch one hole for multiple units, be sure to adjust the standard panel cutout dimensions as shown here; otherwise the meters will not fit properly in the hole.

Mounting multiple units is quick and easy. Install the first meter (bottom unit first if stacking vertically). Position the next mounting bracket snugly against the first one, and slide the second meter into place. Repeat for remaining units.

Vertical

Standard cutout

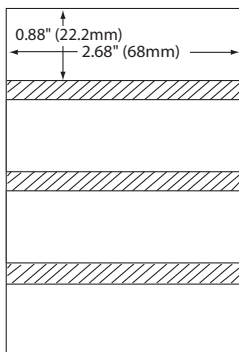

0.071" (1.8mm)
Add to standard
when stacking

Vertical

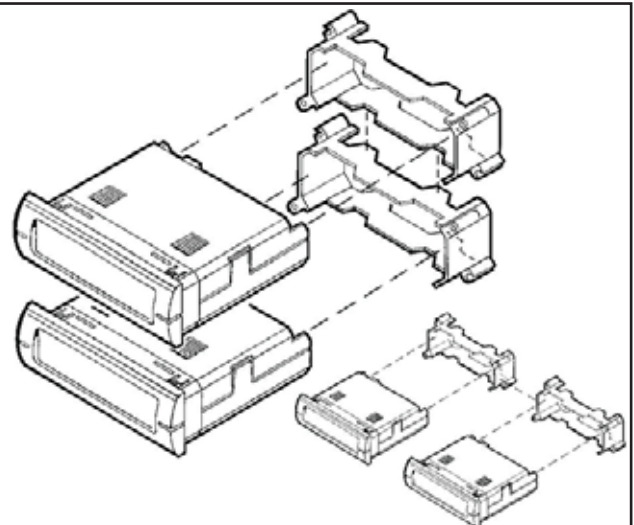

Horizontal

Standard cutout



0.16" (4.0 mm)

Application Example

A company needs to monitor the power supply Voltage and load Current of a 12V, 4 Amp, DC motor.

Voltage: A Mini-Max 20V DC Volt Meter is installed in parallel with the 12VDC power supply. The IN HI+ terminal is connected to the positive lead of the power supply. The IN LO- terminal is connected to the negative lead of the power supply.

Current: A second Mini-Max 5 ADC Ammeter is connected in series with the DC MOTOR. The IN HI+ terminal is connected to the positive lead of the power supply. The IN LO- terminal is connected to the Positive lead of the Dc Motor. The Negative Lead of the DC motor is connected to the negative terminal of the 12VDC supply. The Mini-Max units will indicate the DC Motors supply voltage and load current.

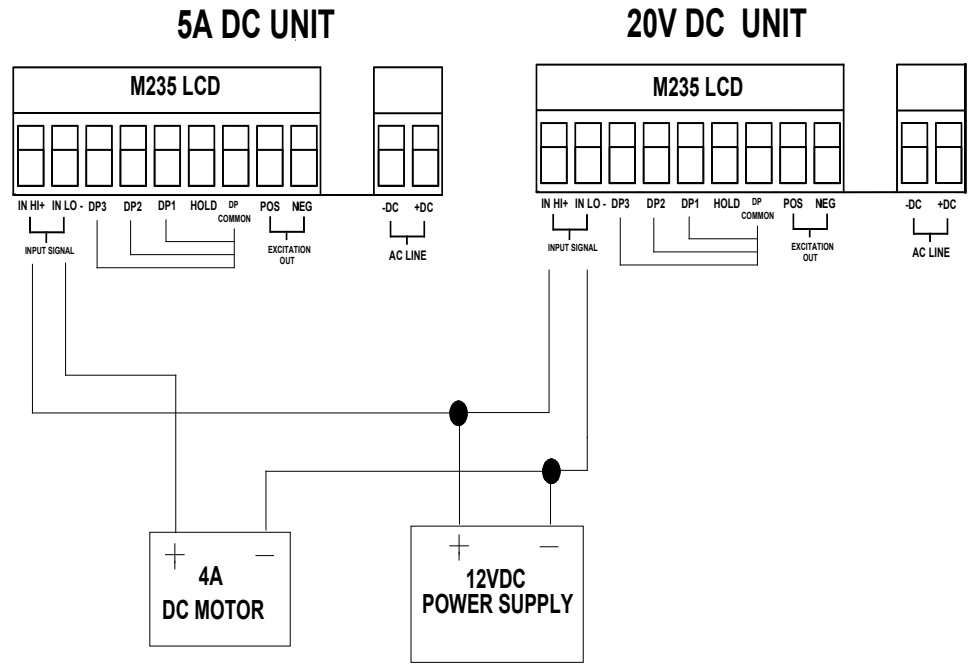

Ordering Information

Your Mini-Max Voltage Indicator can be configured by making an entry for each box

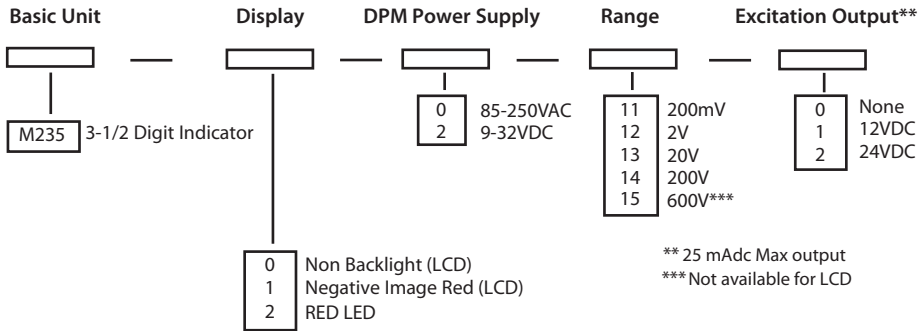

Note: The display Hold feature is standard and user selectable.

Safety Symbols



The WARNING sign denotes a hazard. It calls attention to a procedure, practice, or the like, which, if not correctly performed or adhered to, could result in personal injury.



The CAUTION sign denotes a hazard. It calls attention to an operating procedure, practice, or the like, which, if not correctly adhered to, could result in damage to or destruction of part or all of the instrument.

Accessories

Portable

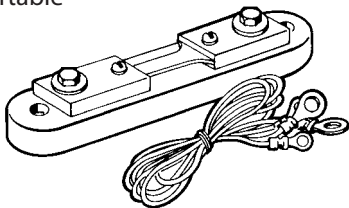

Switchboard

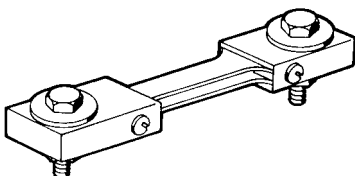

External shunts enable digital meters to indicate higher currents. A shunt is installed in series between the source and load. The shunt produces a DCmV drop which is measured by the Mini-Max meter. The Mini-Max can be scaled to display the actual current between the load and the source. Simpson manufactures portable and switchboard shunts. Each portable shunt includes 5' leads.

Example : 25Amp DC is to be measured. A Mini-Max M235 3 1/2 digit 200mVdc meter and 25Amp shunt, Cat. No. 06707, are selected for this application. 25A dc flowing through the shunt generates 50mV which is applied to the IN HI+ and IN LO- inputs of the meter. The 50mV would normally display as 50.0 on the meter. By using the scale adjustments, the meters scale factor may be adjusted to 1/2. The meter will now display 25.0 thus providing a 25 amp indication.

Ordering Information

Portable Shunts 50mV

Amps	Cat. Number
1	06700
5	06703
10	06704
15	06705
25	06707
30	06708
50	06709
75	06711
100	06713
150	06714
200	06715

Switchboard Shunts 50mV

Amps	Cat. Number
100	06500
150	06503
200	06504
250	06505
300	06506
400	06507
500	06508